

TECHNICAL DATA SAFETY EDGE GR-757

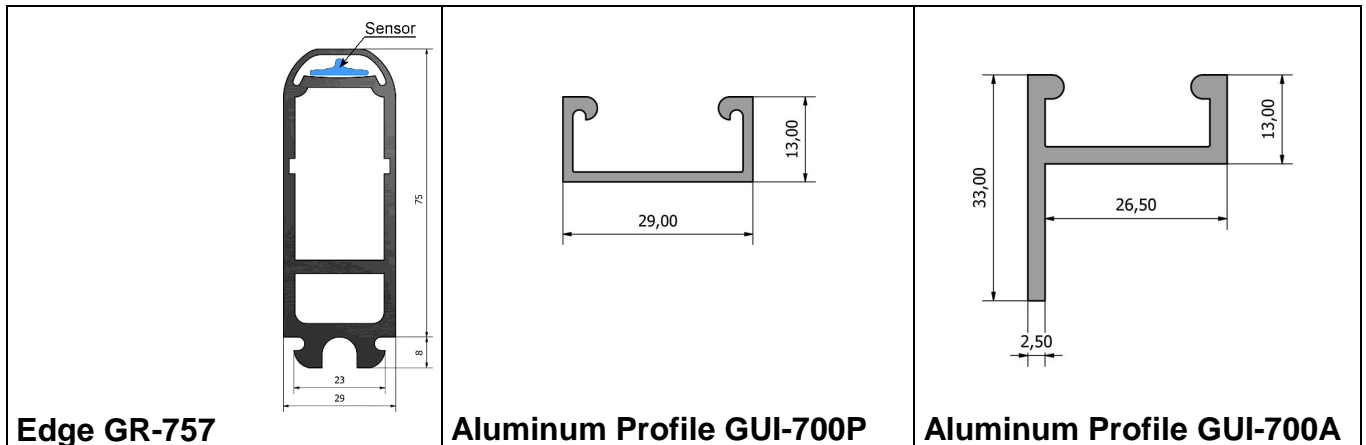

Dimensions are in mm, rubber tolerance according to DIN ISO 3302-1 class E2.

GENERAL CHARACTERISTICS

Model	GR-757
Material	EPDM
Application	Suitable for fingers detecting
Cable material	PVC
Protection degree	IP56 or IP65
Internal contact	Normally open
Operating temperature	-10 + 65°C @ 10mm/s 0 + 65°C @ 100mm/s

Weight	1.1 Kg / m
Material hardness	70 shore
Number of operations	> 2.000.000
Effective sensing angle	20°
Sensor mounting orientations	A, B
Max length	60 m
Dead zone	25 mm

ELECTRICAL CHARACTERISTICS

DESCRIPTION	VALUE
Electrical resistance	0.6 Ohm / m
Max current	1 A
Max voltage	32 Vdc
Max length cable	250 m copper - 0.35 mm ²
Max cable length between edges	Equal to max length of the single edge

CHEMICAL COMPATIBILITY

SUBSTANCE	EFFECT (note 1)	CONTACT (note 2)
Alcohol	no effect	permanent
Water	no effect	permanent
Hydrocarbons	extreme	avoid
Dilutes base	few	some
Dilutes acid	few	some
Vegetable oils	severe	very brief
Oxidizing acids	extreme	avoid
Not oxidizing acids	few	some

Nota 1 Effects that are found on the surface after contact with substance.

Nota 2 Type of contact between edge and substance.

This list is only a guideline. The customer, in critical applications, should test the edge with the substance.

MECHANICAL CHARACTERISTICS

DESCRIPTION	Speed 10 mm/s
Pre-travel	1.3 mm
Working travel 250N	36.7 mm
Working travel 400N	44.0 mm
Working travel 600N	47.4 mm
Overtravel 250N	35.4 mm
Overtravel 400N	42.7 mm
Overtravel 600N	46.1 mm
Actuating force test rod 20mm	20 N @ 20°C
Actuating force test rod 80mm	66 N @ 20°C
Mechanical force	500N

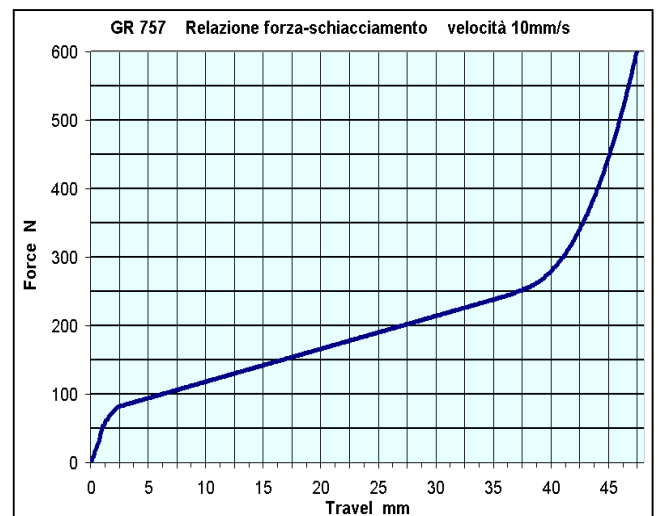

Tested according EN 13852-2,

test rod 80mm actuating point C3, temperature 20°C



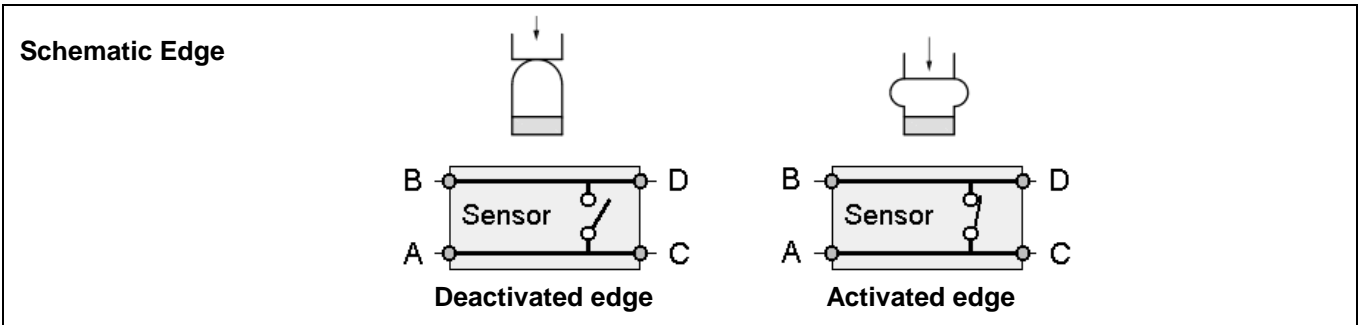



ATTENTION: activation angle is less than 90°

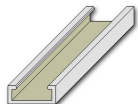
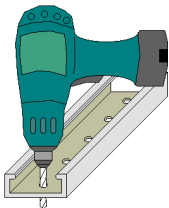

The sensitive edge GR-757 is compliant with EN 13856-2. The edge in combination with PS3-Ax control module can reach the CAT 3 - PL e how indicated in the ISO 13849-1 standard. Consider this value of PL to calculate the PL of the machinery where this safety device is installed. The category and the PL declared for the device shall comply with the categories and PL established by the user's risk analysis.
 The response time it is the time between the edge is touched and the internal contact is closed. This time depends by pre-travel and the pressing speed of the edge.

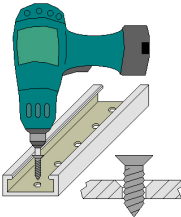
Response time = pre-travel [mm] / speed of crushing of the edge [mm/sec]
 Example: pre-travel = 1,3 mm; speed of crushing = 50 mm/sec; response time = 1,3 / 50 = 0,026 sec.

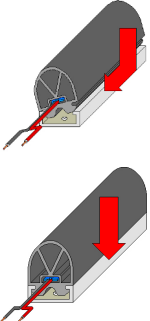
ASSEMBLY INSTRUCTION

	<p>To facilitate installation of the sensitive edge can be used the suitable aluminium profile. This profile is provided on customer request.</p>								
	<p>With a drill, pierce the aluminium profile. The holes must be distributed evenly over the entire length. Follow this guideline:</p> <table border="1" data-bbox="641 1160 1198 1290"> <tr> <td>Hole size</td> <td>5 mm</td> </tr> <tr> <td>Screw size</td> <td>5mm - countersunk</td> </tr> <tr> <td>Hole size for cable</td> <td>10 mm</td> </tr> <tr> <td>Distance between holes</td> <td>300 mm</td> </tr> </table> <p> The holes must be countersunk in function of the size of the screw. The holes for the cables must be carefully cleaned from any burrs that may cause cables damage.</p>	Hole size	5 mm	Screw size	5mm - countersunk	Hole size for cable	10 mm	Distance between holes	300 mm
Hole size	5 mm								
Screw size	5mm - countersunk								
Hole size for cable	10 mm								
Distance between holes	300 mm								
	<p>Once drilled the aluminium profile, can be attached to its supporting surface.</p> <p> There must not be a thickness between the plane of the profile and the screw head.</p>								
	<p>To easier make fitting, spray with a soapy water the aluminium profile and/or the edge. Do not use durable lubricants (oils or similar) to prevent a subsequent slipping of the edge.</p> <p> The insertion of the edge into the aluminium profile must never be carried for longitudinal insertion, or worse, pulling the connection cables. This methodology of edge insertion causes damage to internal sensor and connection cable.</p>								

OVERTRAVEL



The response time of the control unit (for example PS3-Ax) influences the measurement of the overtravel value of the sensitive edge. For the selection of the most suitable type of edge for your application see the Annex C in the EN 13856-2 regulations.

DEAD SURFACES

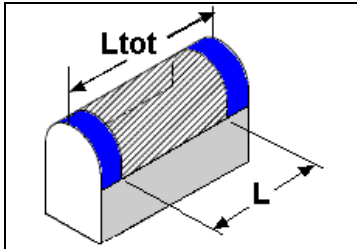

L is the effective sensitive length of the sensitive edge. **Ltot** is the total length of the sensitive edge. In blue are represented the dead surfaces (inactive zone) of the sensitive edge. Refer to the table of the general characteristics for the maximum length of the dead surfaces. The size of the inactive zones is equal by both parts. The value of the sensitive length, for the GR757 sensitive edge is:

$$L (\text{mm}) = L_{\text{tot}} (\text{mm}) - 25\text{mm} - 25\text{mm}$$

SERVICE AND TEST

Each repair operation should be performed only by GREIN authorized technicians.

Putting into service and tests at regular intervals

The installer who put in service the equipment should have all the information on the machine, the control module and the safety sensitive edge. The test must cover the interaction between the components previously mentioned and the control power system in accordance with the safety laws. The test relevant information provided by the machine or plant manufacturer shall always be observed when testing. The frequency of the periodic tests must be in accordance with the requirements of national law.

Testing prior to put a device into service for the first time and after modifications

A person authorized and qualified, should test the GR757 safety sensitive edge and control unit connected to it, the first time it is put into service. All changes on the mounting configuration of the GR757 sensitive edge, its replacement and the settings of the control unit must always be evaluated by a qualified and authorized person.

Periodic test

The periodic tests are performed to detect and remove the deficiencies relevant to safety. Types, scope and time intervals to be followed, are listed in the "SETTINGS AND TEST". For all tests, must be complied with requirements of national law. Test results must be recorded and signed by an inspector. The report must be kept at the place of installation of the machine or system.

SETTING AND TEST

Daily testing of the protective device by authorized personnel.



The overall security of the machinery and the security device(s) depends on the quality, reliability and proper installation between the various parts relegated to security. The machine must not be restarted if there is a dangerous situation.

Check the following points:

- proper installation (see installation chapter),
- damage or wear of the surface of the GR757 sensitive edge,
- wear or damage to the connecting cables between the GR757 sensitive edge and the control of the machinery

If the above points are correct, check that:

- 1) if no force acts on the GR757 sensitive edge or is less than the activation force, the control machine permit the machinery operation ;
- 2) if a force acts on the GR757 sensitive edge and is greater than the force of activation, the machine control must intervene to lock and maintain the machine in safety.

TROUBLESHOOTING

With a multimeter set on the continuity test, check that on edge deactivated, between the terminals A-B and C-D there is a normally open circuit. Otherwise, if the edge is activated, between the terminals A-B and C-D there is a normally close circuit. In all case between the terminals A-C and B-D there is always a short circuit.

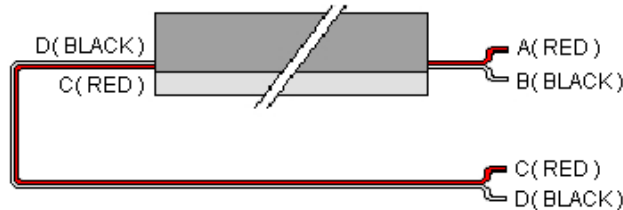

NOTE

If a GREIN PS3-AX control unit is used, for more information on troubleshooting refer to PS3 Instruction manual.

MAINTENANCE OPERATION



The maintenance instructions must be read before any maintenance to the machine, the control unit and sensing element. All machine parts removed for maintenance operations must be restored, if these parts are not properly attached, the device performance may be affected.

Periodically the edge should be clean from materials that may damage it.

Do not use solvents or other substance that can damage the surface (see table of the chemical compatibility).

SPARE PARTS



Only parts approved by the manufacturer may be substituted. If used unauthorized parts, or changes are made to the safety sensitive edge, the device performance may be affected.

PACKING AND UNPACKING

Always observe the standards and regulations regarding the prevention of accidents when handling the product. The shape, size and contents of the package varies depending on the number and type of edges.

UNPACKING GUIDELINES

When unpacking the product, follow these guidelines:

- 1 inspect the package to check damaged or missing items;
- 2 proceed with unpacking paying particular attention to the opening of the package, if a cutter is used be careful not to damage the surface of the product;
- 3 do not pull out from the pack by pulling from the connection cables.

HANDLING GUIDELINES

To prevent damage or personal injury follow these guidelines when handling the product:

- 1 pay attention during handling of the product;
- 2 leave the product in its original packaging as long as possible.

STORAGE

If the product is not installed immediately after delivery, store it in a dry place at temperature range between -10 +60 °C, straight and not coiled to avoid permanent deformation of the rubber

DISPOSAL

Dispose of this product and its components in accordance with state and local laws / regulations.